

900 Series



15

Steel Laminated Padlocks

The innovative interlocking construction of the 900 series enables this product to achieve exceptional levels of impact resistance. This feature, in combination with a pick resistant pin tumbler mechanism and secure bolt locking system, offers unusually high standards of reliability and security. The high quality attractive finish, enhanced by a vinyl bumper which protects both product and the article being secured, is durable. The unique specification makes the 900 series suitable for many applications and justifies the popularity of this range.



General Specification

- Function – open sprung shackle
- Single locking – size 30mm
- Double locking – sizes 40, 50, 60mm
- Laminated steel body
- Hardened steel shackle – 56-58 HRC
- Protective vinyl bumper
- 4 or 5 pin tumbler mechanism
- Anti pick drivers
- Anti pick key profile
- Large range of key combinations
- 2 brass keys, nickel plated

Technical Specification

| | 30mm | 40mm | 50mm | 60mm |
|-----------|--------|--------|--------|--------|
| Size A mm | 31.75 | 41.28 | 51.00 | 60.50 |
| Size B mm | 27.00 | 37.00 | 40.00 | 46.00 |
| Size C mm | 23.75 | 22.25 | 28.50 | 33.50 |
| Size D mm | 6.25 | 6.50 | 9.50 | 11.00 |
| Size E mm | 14.25 | 20.50 | 22.25 | 28.50 |
| Size F mm | 20.00 | 26.00 | 30.00 | 33.00 |
| No. pins | 4 | 4 | 5 | 5 |
| Locking | Single | Double | Double | Double |

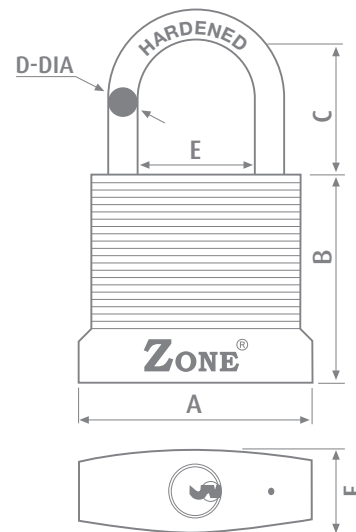

15