

950 Series



Combination Steel Laminated Padlocks

The innovative interlocking construction of the 950 series enables this product to achieve exceptional levels of impact resistance. This feature, combined with an easy to change, 4 wheel, 10 digit combination mechanism and secure bolt locking system, offers high standards of reliability, security and convenience. The high quality attractive finish, enhanced by a vinyl bumper which protects both product and the article being secured, is durable. The unique specification makes the 950 series suitable for many applications and justifies the popularity of this range.



General Specification

- Function – open sprung shackle
- Double locking
- Laminated steel body
- Hardened steel shackle – 56-58 HRC
- Protective vinyl bumper
- 4 wheel resettable combination
- Standard and long shackle versions available

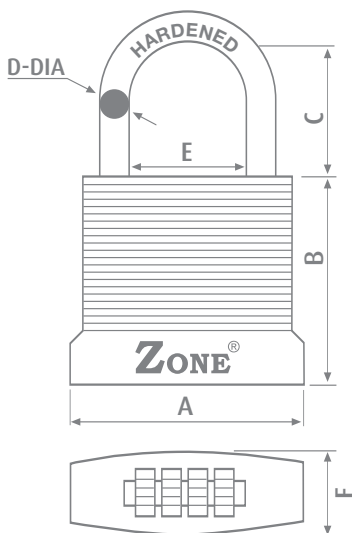

Technical Specification

	50mm	50 x 70mm
Size A mm	50	50
Size B mm	40	40
Size C mm	28	68
Size D mm	8	8
Size E mm	24	24
Size F mm	30	30
No. pins	N/A	N/A
Locking	Double	Double